

- ALL DIMENSIONS ARE IN MILLIMETRES (mm) UNLESS NOTED OTHERWISE.
- AN INSPECTION CHAMBER SHOULD BE LOCATED AT OR WITHIN 1m OF THE PROPERTY BOUNDARY AT THE UPSTREAM END OF EACH SERVICE CONNECTION ON THE PRIVATE SIDE OF THE CURBLINE. IF PRACTICABLE, CONSULT WITH IRISH WATER OR ALTERNATIVE LOCAL AUTHORITY.
- SERVICE CONNECTION FROM PUBLIC SEWER TO PROPERTY BOUNDARY IS A PUBLIC ASSET. PIPE UPSTREAM OF THE PROPERTY BOUNDARY IS A PRIVATE ASSET AND SHOULD BE CONSTRUCTED IN ACCORDANCE WITH THE RELEVANT LOCAL AUTHORITY REQUIREMENTS.
- ACCESS POINTS SHOULD BE LOCATED SO THAT THEY ARE ACCESSIBLE AND APPROPRIATE TO THE MANHOLE AT ALL TIMES FOR USE. THEY SHOULD AVOID REAR GARDENS OR ENCLOSED LOCATIONS AND SHOULD NEVER BE OVERLAIN WITH SURFACE DRAINAGE, TROTTIL, ETC.
- COVERS AND FRAMES SHALL BE SUITABLE FOR ROAD AND TRAFFIC CONDITIONS SUBJECT TO REVIEW BY IRISH WATER.
- 200mm ALL AROUND, 100mm DEEP CONCRETE PLINTH AROUND COVERS IN OPEN AREAS.
- IF THE PROPERTY DESIGNATED CHAMBER WITS MAY ALSO BE USED, SUBJECT TO REVIEW BY IRISH WATER - SEE DETAIL BELOW.
- CHAMBERS SHALL BE SURROUNDED BY A MINIMUM OF 150mm COMPACTED CLAUSE 8M OR CLAUSE 8M MATERIAL AS PER STD-WW-07.
- MAXIMUM DEPTH FROM COVER LEVEL TO SOFFIT OF PIPE: 1.2m. INTERNAL DIMENSIONS GREATER THAN 800 x 800mm OR 800mm Ø SHALL BE NOTED IN ACCORDANCE WITH MANUFACTURER'S RECOMMENDATIONS.
- SMALLER INSPECTION CHAMBERS WITH INTERNAL DIMENSIONS OF 800mm Ø OR 800 x 800mm MAY BE PERMITTED SUBJECT TO APPROVAL BY IRISH WATER WHERE CONVENIENT PHYSICAL CONDITIONS EXIST.
- PRE-INSULATED CHAMBERS SHOULD HAVE WATER TIGHT JOINTS AND SHOULD BE INTERLOCKED TO PREVENT LATERAL MOVEMENT OF INDIVIDUAL SECTIONS OF THE UNIT.

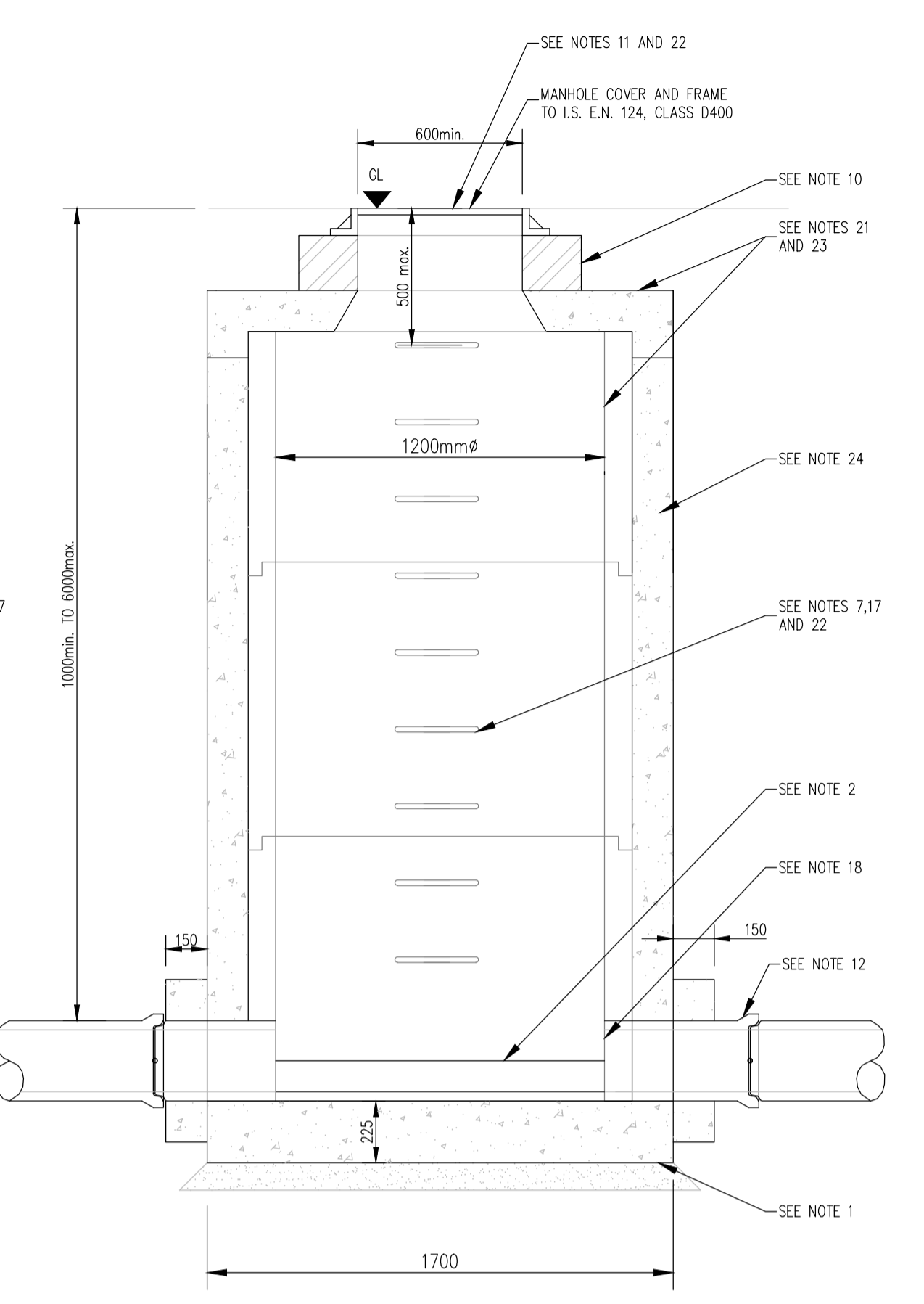
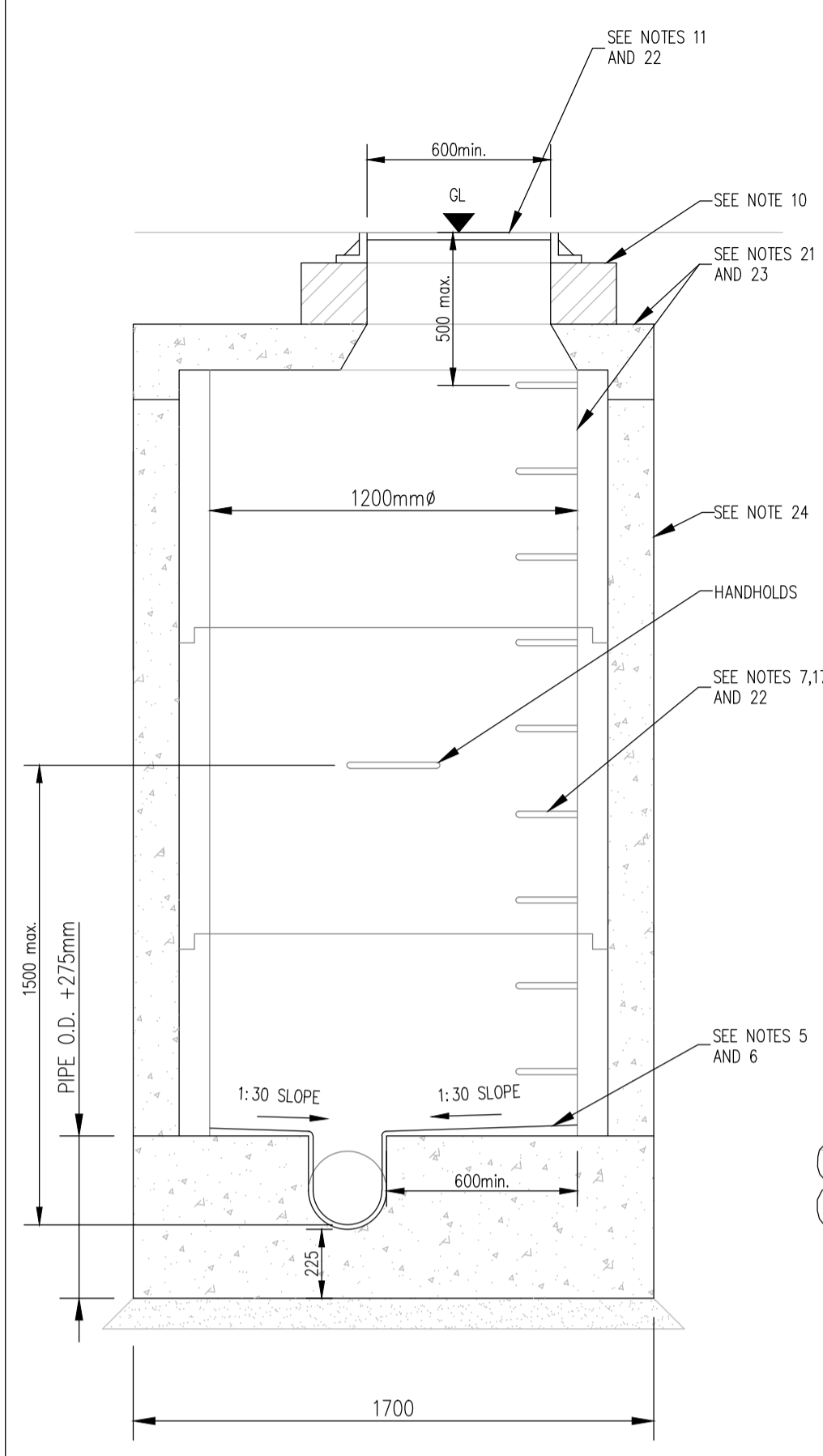

TYPE J MANHOLE (PRECAST)  
SECTION A-A  
SCALE 1:20

TYPE J MANHOLE (PRECAST)  
SECTION B-B  
SCALE 1:20

MANHOLE PIPE DIAMETER A	CHAMBER INTERNAL DIAMETER B
225mmØ	1200mmØ
300mmØ	1200mmØ
375mmØ	1200mmØ
450mmØ	1200mmØ
525mmØ	1200mmØ
600mmØ	1200mmØ
675mmØ	1350mmØ
750mmØ	1350mmØ
900mmØ	1500mmØ
1050mmØ	2100mmØ
1200mmØ	2100mmØ

NOTE:  
CHAMBER COVERS TO BE CLASS D400

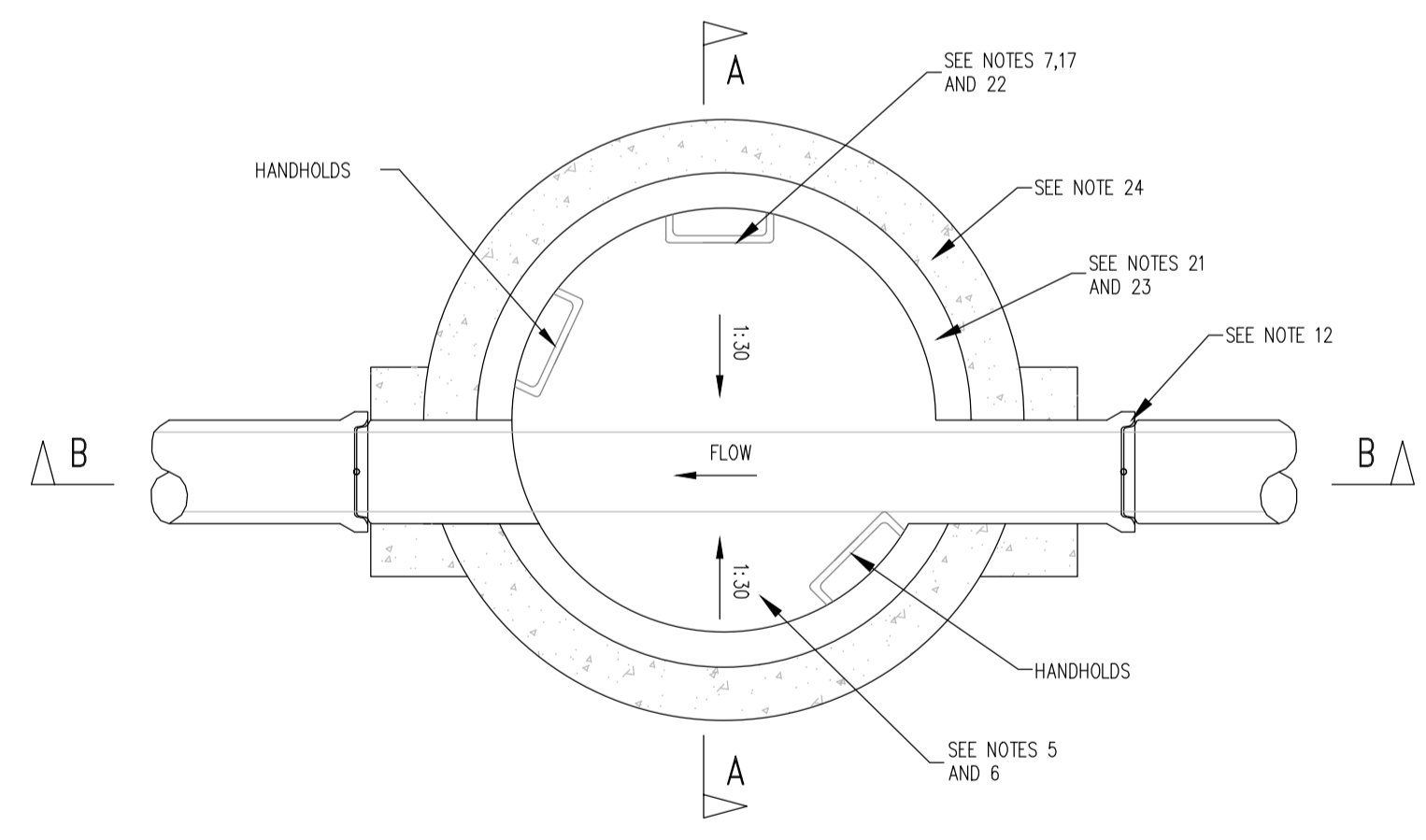

- NOTES :**
- 225mm THICK CL.20N/20mm MASS CONCRETE FOUNDATIONS.
  - PREFORMED HALF CIRCLE CHANNEL PIPES, THE PIPELINE MAY, WHERE PRACTICABLE, BE LAID THROUGH THE MANHOLE AND THE CROWN CUT OUT TO HALF DIAMETER, PROVIDED FLEXIBLE JOINTS ARE SITUATED ON EACH SIDE NO FURTHER THAN 600mm FROM THE INNER FACE OF MANHOLE WALL.
  - MANHOLE CONSTRUCTION
    - FOR SURFACE WATER MANHOLE HIGH DENSITY BLOCKS TO CL.S10 OF IS.20 PART 1:1987 OR CL. 30N/20mm INSITU CONCRETE.
    - BLOCK WORK SHALL BE BEDDED AND JOINTED USING MORTAR TO IS406. BEDS AND VERTICAL JOINTS SHALL BE COMPLETELY FILLED WITH MORTAR AS THE BLOCKS ARE LAID.
    - JOINTS SHALL BE FLUSH POINTED AS THE WORK PROCEEDS.
    - BRICK TO BE BONDED TO BLOCK WORK USING ENGLISH GARDEN WALL BOND.
  - RELIEVING ARCH FORMED BY 215x103x65 SOLID ENGINEERING BRICK CLASS A OR B AS PER DRAWING. RELIEVING ARCHES USED IN BRICK OR BLOCK WORK MANHOLES EXTEND OVER FULL THICKNESS OF WALL. A DOUBLE ARCH IS TO BE FORMED FOR PIPE DIAMETERS GREATER THAN 600mm.
  - BENCHING AND PIPE CHANNEL PIPE SURROUND-0.20/20 CONCRETE.
  - BENCHING FINISHED IN 2:1 SAND-CEMENT MORTAR WITH A SMOOTH TROWEL FINISH, AT 1:13 SLOPE TOWARDS CHAMBER.
  - STANDARD RUNGS AT 300 CENTRES VERTICALLY AND GALVANISED TO THE LATEST VERSION OF B.S.729 OR EQUIVALENT. NOTE: STEP IRONS ARE NOT ACCEPTABLE.
  - 600mm SQUARE OPE IN ROOF SLAB.
  - PRECAST R.C. ROOF SLAB SHALL BE 200mm THICK IN CLASS 30N/20mm, WITH 40mm COVER TO STEEL.
  - 1 TO 2 COURSES OF SOLID ENGINEERING BRICKS CL.B TO I.S.91:1983 SET IN 1:3 (CEMENT AND MORTAR).
  - CLASS D400 OR E600 MANHOLE COVER AND FRAME TO IS/EN 124. 150mm DEEP FRAME FOR ROADS AND 100mm DEEP FOR FOOTPATHS AND GREEN AREAS. NON-ROCK DESIGN, CLOSED KEYWAYS, MANUFACTURED FROM SPHEROIDAL GRAPHITE CAST IRON (DUCTILE CAST IRON), 600x600 (600mmØ) CLEAR OPENING, COVER AND FRAME COATED IN BITUMEN OR OTHER APPROVED MATERIAL. COVER TO HAVE A MINIMUM MASS OF 140KG/m², FRAME BEARING AREA SHALL BE 80,000mm² MIN. FRAMES SHALL BE DESIGNED TO PREVENT COVERS FALLING INTO MANHOLE. FRAMES SHALL BE BEDDED ON APPROVED MORTAR TO MANUFACTURERS INSTRUCTIONS.
  - SHORT LENGTH PIPE AND PIPE JOINT EXTERNAL TO MANHOLE SHALL NOT EXCEED 600mm FROM THE INNER FACE OF MANHOLE WALL.
  - TOE HOLES OF 230mm MINIMUM DEPTH AND GALVANISED STEEL SAFETY RAILINGS TO BE PROVIDED IN BENCHING OF SEWERS GREATER THAN 525mm DIAMETER AND DEPTH TO INVERT 3m FOR ACCESS TO INVERT.
  - WHEN DEPTH OF MANHOLES TO INVERT IS GREATER THAN 3.0m LADDERS SHALL BE USED INSTEAD OF RUNGS TO B.S.4211 OR EQUIVALENT EXCEPT THAT STRINGERS SHOULD BE NOT LESS THAN 65x12mm IN SECTION AND RUNGS 25mm IN DIAMETER. FIXED LADDERS SHOULD MEET THE DIMENSIONAL REQUIREMENTS OF B.S.4211 OR EQUIVALENT.
  - LADDER STRINGERS SHOULD BE ADEQUATELY SUPPORTED FROM THE MANHOLE WALL AT INTERVALS OF NOT MORE THAN 2.0m, STRINGERS SHOULD BE BOLTED TO CLEATS TO FACILITATE RENEWAL.
  - ALL LADDERS, RUNGS, HANDRAILS, SAFETY CHAINS ETC. SHALL BE HOT DIP GALVANISED TO B.S.729 OR EQUIVALENT.
  - PIPE SHOULD BE CUT FLUSH WITH THE INSIDE SURFACE OF THE MANHOLE WALL SO THAT THE CHANNEL EXTENDS THE FULL LENGTH OF THE MANHOLE (EXCEPT FOR PRECAST MANHOLES).
  - POSITION OF 910 SQUARE OPE IN INTERMEDIATE ROOF SLAB.
    - ALL MANHOLES SHALL BE WATER TIGHT TO THE SATISFACTION OF THE ENGINEER.
    - FORMWORK TO REINFORCED CONCRETE AND MASS CONCRETE SHALL COMPLY WITH CLASS 2, SECTION 6.2.7, B.S.8110:PART 1:1997.
    - FINISH TO THE TOP OF SLABS SHALL COMPLY WITH TYPE A, SECTION 6.2.7, B.S.8110: PART 1:1997.
    - PLAN DIMENSIONS OF MANHOLE ARE BASED ON BLOCK WORK HAVING A COORDINATING SIZE OF 350x225x100.
    - MANHOLES ARE DESIGNED TO B.S.8005 AND WALL THICKNESS TO LS.325 BLOCK WORK DESIGN CODE TAKING GRANULAR FILL, PRESSURE AND H.B. SURCHARGE.
    - REINFORCEMENT TO SLABS TO ENGINEERS DETAILS.
  - FOR MANHOLES >3m DEPTH TO INVERT USE 30N/20mm INSITU CONCRETE. REINFORCING MESH REF. A393Ø 6.16KG/m TO BE FIXED AT MID POINT OF WALL. ADDITIONAL REINFORCEMENT TO BE SUPPLIED OVER PIPE CROWN.
  - FOR PRECAST MANHOLES, CHAMBER WALLS AND COVER SLAB TO BE CONSTRUCTED TO IS EN 1917 AND IS 420 2004.
  - MANHOLE OPENINGS TO BE SITUATED FURTHEST FROM THE NEAREST CARRIAGEWAY. MANHOLE STEPS/ACCESS TO BE POSITIONED TO ALLOW VIEWING OF ONCOMING TRAFFIC.
  - FOR BEDDING AND SEALING OF CHAMBER RUNGS, THE TOP RING (TO PRECAST COVER SLAB AND BOTTOM RING TO BE BEDDED WITH CEMENT MORTAR. FOR INTERMEDIATE RUNGS, JOINTS TO BE SEALED WITH APPROVED PRE-FORMED JOINTING STRIP.
  - PRECAST MANHOLES TO BE SURROUNDED WITH A MINIMUM OF 150mm THICK GRADE C8 CONCRETE.
  - THIS DRAWING SHALL BE READ IN CONJUNCTION WITH THE SPECIFICATION.
  - DO NOT SCALE FROM THIS DRAWING USE STATED DIMENSIONS ONLY. IF IN DOUBT CONSULT THE ENGINEER.
  - LEVELS REFER TO O.S. DATUM MALIN HEAD.
- GENERAL NOTES**
- ALL BRICK TO BE SOLID ENGINEERING BRICK CLASS A OR B.
- FOR PIPE DIAMETER >750mm USE MANHOLE WITH INTERNAL SIZE=PIPE SIZE + 1mETRE + 300mm.
- DISTANCE FROM THE TOP RUNG OF THE LADDER TO GROUND LEVEL MUST BE A MAXIMUM OF 500mm.

SURFACE WATER MANHOLES TO CAVAN COUNTY COUNCIL SPECIFICATIONS  
SCALE : 1/20

**PLANNING DRAWING.**  
NOT FOR CONSTRUCTION.  
ALL LEVELS GIVEN ARE  
RELATIVE TO ORDNANCE DATUM.  
THIS DRAWING HAS BEEN ISSUED FOR INFORMATION  
PURPOSES ONLY AND MUST NOT BE USED  
FOR CONSTRUCTION UNDER ANY CIRCUMSTANCES

- NOTES**
- For setting out refer to Architect's drawings.
  - This drawing to be read in conjunction with all other Architectural and Engineering drawings and all other relevant drawings and Specifications.
  - DO NOT SCALE THIS DRAWING. Use figured dimensions only.
  - No part of this document may be reproduced or transmitted in any form or stored in any retrieval system of any nature without the written permission as copyright holder except as agreed for use on the project for which the document was originally issued.
  - Ordnance Survey Ireland Licence Number EN 0074024

Rev. No.	Date	REVISION NOTE
P1	17.07.2023	ISSUED FOR STAGE 2
P2	22.02.2024	ISSUED FOR PLANNING

Rev. No.	Date	REVISION NOTE	Drn. By	Chkd. By
			SC	NB
			SC	LJ

Architect	Michael Fitzpatrick (MFA)
Project	Drumclark Development Co. Cavan
Title	Proposed Drainage Details Sheet 2
Dwg. No.	D111-CSC-XX-XX-DR-C-0005
Date	June 2023
Drn. by	SC
Chkd. by	JF
Aprvd. by	NB
Scale	As Shown @ A1
Revision	P2

**CS Consulting Group**  
DUBLIN | LONDON | LIMERICK

Head Office  
19-22 Dame Street, Dublin 2.  
T: +353 (0)1 5480863  
e: info@csconsulting.ie  
w: www.csconsulting.ie

Quality  
Environment  
Energy  
Health & Safety

IS. EN ISO 9001:2008  
IS. EN ISO 14001:2004  
IS. EN ISO 50001:2011  
OHSAS 18001:2007